



MW-1519A / Engine Dynamometer



Example Model Shown
(Image may not depict all standard included components)

MW-1519A Eddy Current Dynamometer

Specifications

Power:	300 hp (224 kW)
Max Torque at Base Speed:	1,576 lb-ft (2,136 Nm)
Base Speed:	1,000 rpm
Max. Speed:	5,000 rpm
Construction Type:	Dry Gap
Rotor Inertia:	111 lb-ft ² (4.68 kg-m ²)
Coolant Required at Max. Power:	30 gpm (113.6 lpm)
Coolant Inlet (Min-Max):	55-100 psi (378-689 kPa)
Coolant Inlet Temperature Max:	90°F (32.2°C)
Shipping Weight (estimate):	5,000 lb (2,268 kg)
Companion Flange / Hub Pattern:	1810 - US Customary
Coil Voltage / Hot Amperage:	90V / 10.52 amps
Rotation:	bi-directional

For overhung loads, such as a belt or gear drive, please contact Dyne Systems to ensure that the system will meet the required performance needs.

Recommended Accessories

- Driveshaft - 1810
- Torsional Coupling - 1810
- Flywheel Adapter Plate Kit
- Driveshaft Guard
- Sub-Base Kit
- Engine Cart
- Air or Electric Starter
- Charge Air Cooler
- Water Recirculating System

Everything you need to succeed

Optional Accessories



Optional Manual
Shaft Lock



Optional Closed Loop
Cooling Center



Optional Charge
Air Cooler



Optional Driveshaft Guard



Optional Engine Cart

Various Facility Support Systems and Services Available



Bulk Fuel Storage
and Distribution



Coolant Storage
and Distribution



Water
Recirculation



Design, Project
& Construction
Management Services

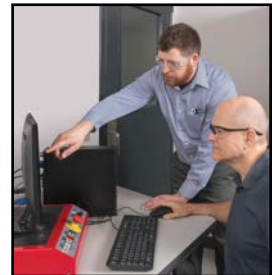

Commissioning,
Start-up & Training

MW-1519A (US Customary)

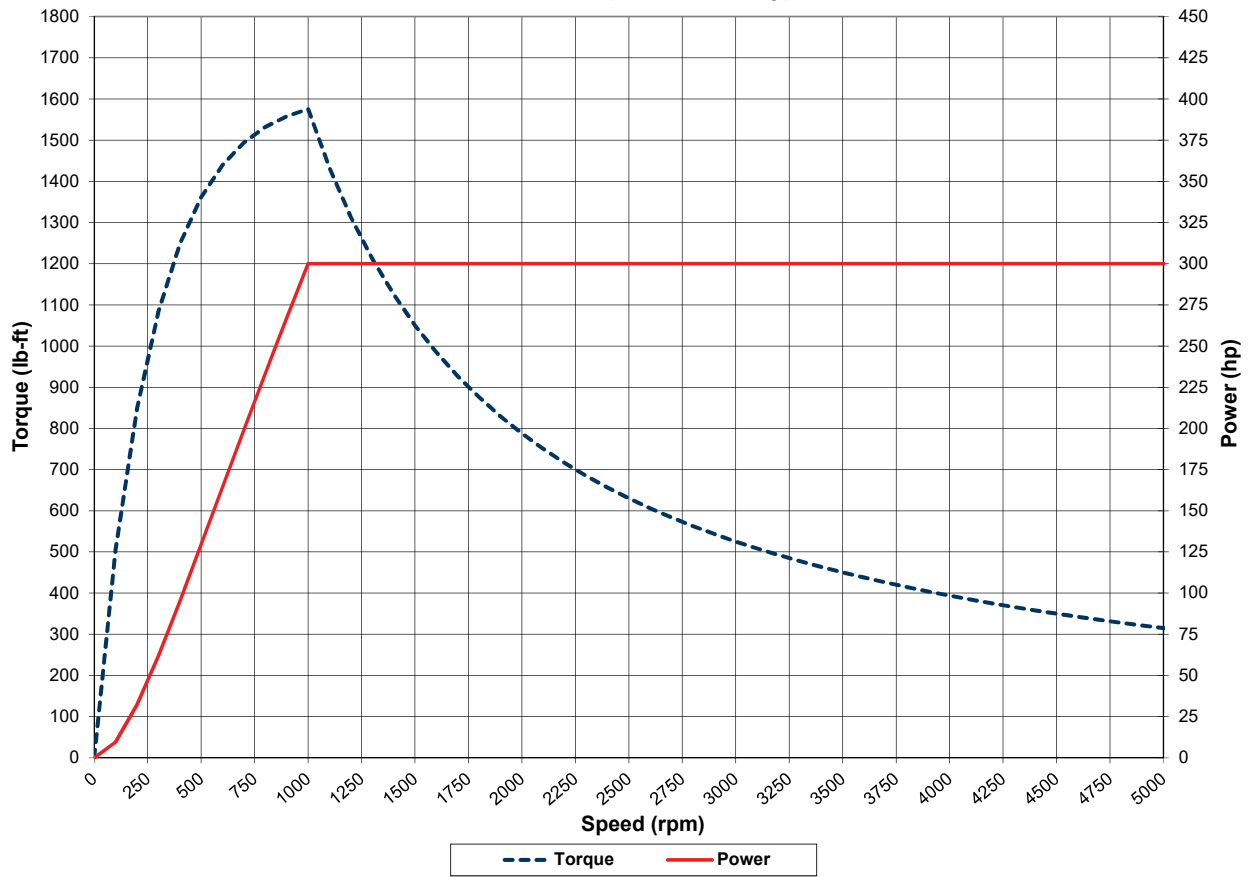

MW-1519A (S.I.)

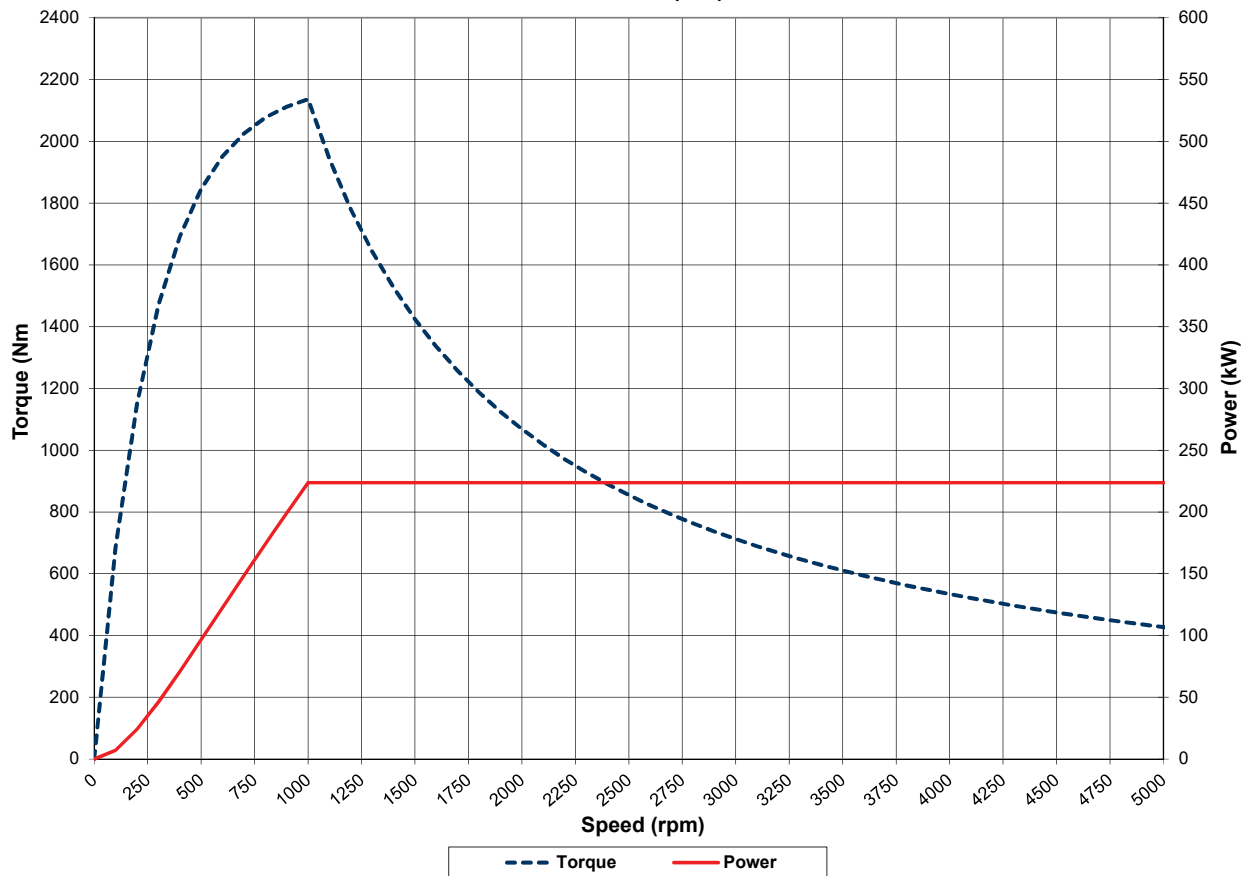

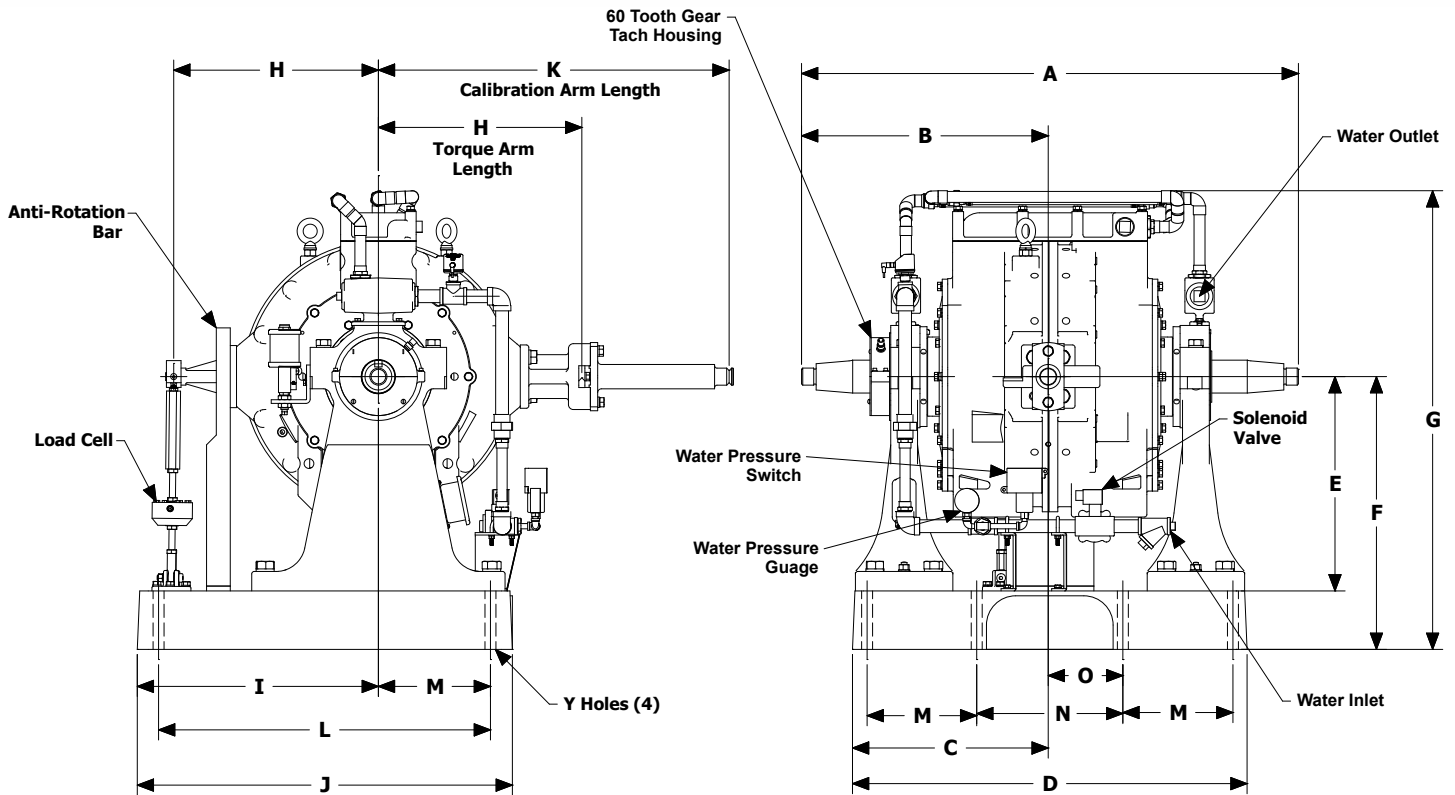

Note: Shown without companion flange

Units	A	B	C	D	E	F	G	H
US Customary	51	25.5	20.25	40.5	22	28	47	21
S.I.	1,295	648	514	1,029	559	711	1,194	533

Units	I	J	K	L	M	N	O	Y
US Customary	24.75	38.5	36	34	11.25	15	7.5	1.13
S.I.	629	851	941	864	286	381	191	29

(All dimensions are for new OEM supplied units)

Standard Included Components

- Load Cell and Linkage
- Cooling Safety Package
- Calibration Arm
- Calibration Weight Hanger
- Companion Flange / Hub Pattern 1810 - US Customary
- Shaft End Guard
- Magnetic Pickup and 60-tooth Gear

As a safety precaution, Dyne Systems recommends a torsional analysis to uncover any potential torsional problems that exist for each application. This analysis will identify any torsional issues (frequencies) that should be fixed prior to operation. Excessive linear vibration may also create problems that must be mitigated for continued operation. It is the customer's responsibility to ensure that these vibration issues are addressed upon application of the dynamometer. Equipment failures attributed to linear or torsional vibration are not warrantable.

Everything you need to succeed



Dyne Systems is a division of Taylor Dynamometer
(414) 755-0040 www.dynesystems.com

DS2327v003