

## 1910 Driveshaft / Engine Dynamometer

### Specifications

- Continuous Load Rating 9,800 lb-ft (13,290 Nm) with no angular misalignment and  $2^\circ \pm 1^\circ$  slope (parallel offset between 0.5 and 1.5 in. (13 and 40 mm))
- Maximum Recommended Short Duration Load 19,900 lb-ft (26,980 Nm) with no angular misalignment and  $2^\circ \pm 1^\circ$  slope (parallel offset between 0.5 and 1.5 in. (13 and 40 mm))
- Minimum Elastic Limit 31,000 lb-ft (42,030 Nm) represents the maximum torque load the universal joint will transmit instantaneously without brinelling bearings or yield in any part
- Maximum Allowable Speed 4,000 rpm
- Dynamically balanced
- Weight 150 lb (68 kg)

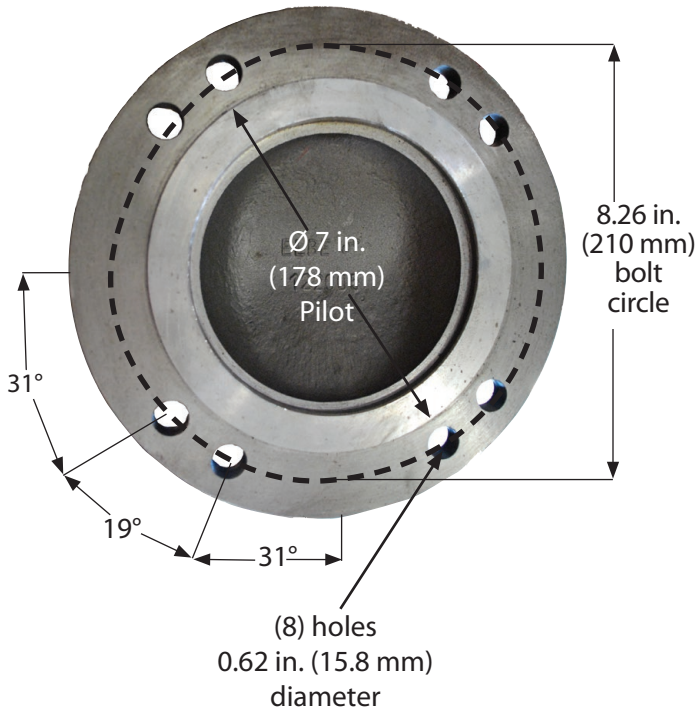

*Everything you need to succeed*