



DM-8102 / Engine Dynamometer



Example Model Shown
(Image may not depict all standard included components)

DM-8102 Eddy Current Dynamometer

Specifications

Power:	450 hp (336 kW)
Max Torque at Base Speed:	762 lb-ft (1,034 Nm)
Base Speed:	3,100 rpm
Max. Speed:	6,000 rpm
Construction Type:	Wet Gap
Rotor Inertia:	17.7 lb-ft ² (0.75 kg-m ²)
Coolant Required at Max. Power:	45 gpm (170.3 lpm)
Coolant Inlet (Min-Max):	55-100 psi (378-689 kPa)
Coolant Inlet Temperature Max:	90°F (32.2°C)
Shipping Weight (estimate):	2,200 lb (998 kg)
Companion Flange / Hub Pattern:	1550 - US Customary
Coil Voltage / Hot Amperage:	90V / 7.3 amps

Recommended Accessories

- Driveshaft - 1550
- Torsional Coupling - 1550
- Flywheel Adapter Plate Kit
- Driveshaft Guard
- Sub-Base Kit
- Engine Cart
- Air or Electric Starter
- Engine Cooling Column
- Charge Air Cooler
- Water Recirculating System

Everything you need to succeed

Optional Accessories



Optional Manual Shaft Lock



Optional Closed Loop Cooling Center



Optional Charge Air Cooler



Optional Driveshaft Guard



Optional Engine Cart

Various Facility Support Systems and Services Available



Bulk Fuel Storage and Distribution



Coolant Storage and Distribution

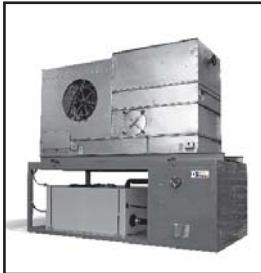

Water Recirculation



Design, Project & Construction Management Services



Commissioning, Start-up & Training

DM-8102 (US Customary)

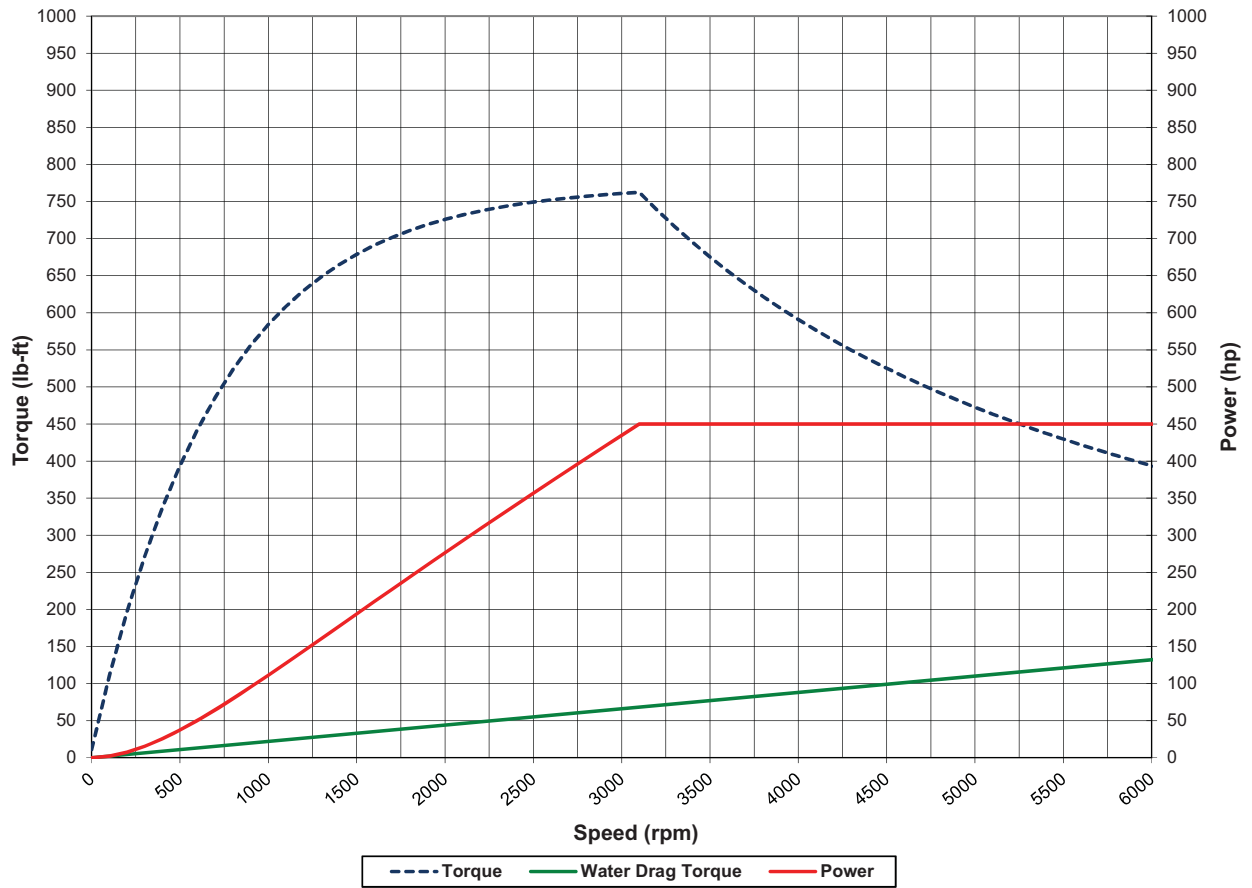

DM-8102 (S.I.)

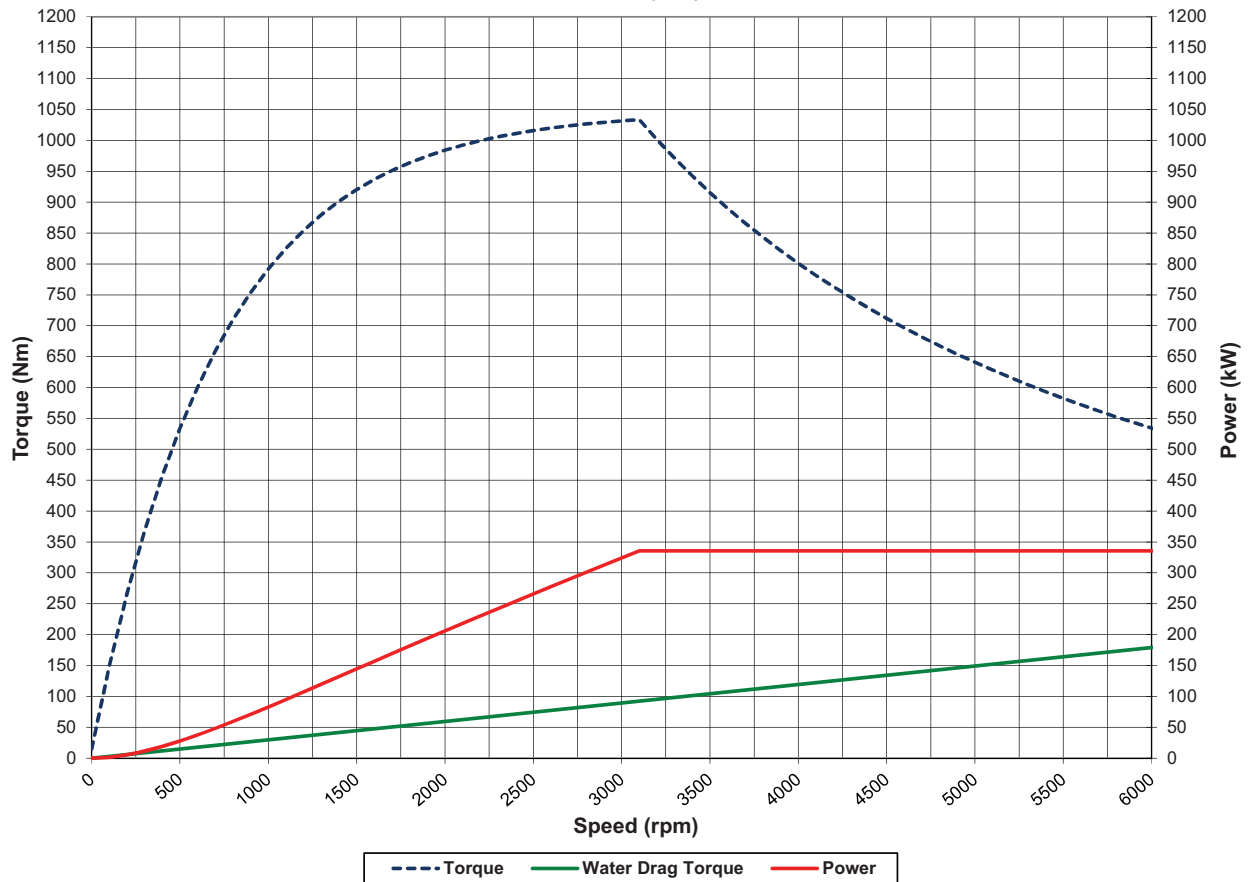

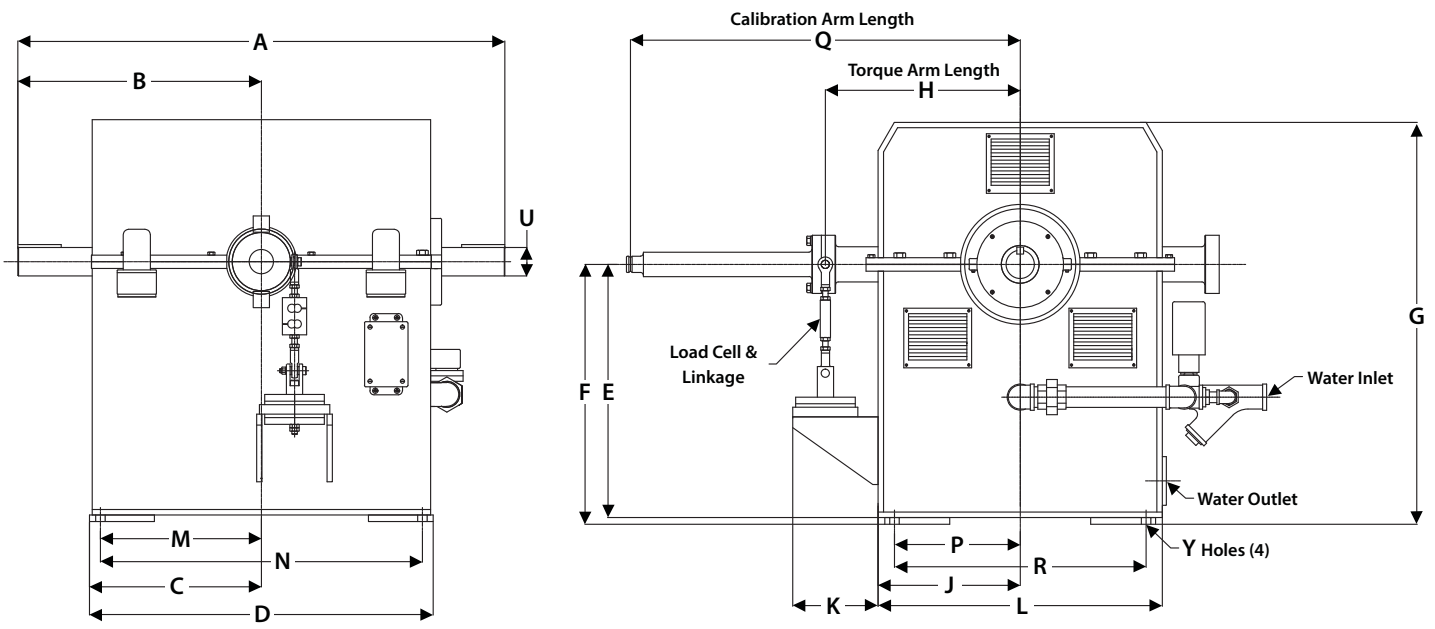

Note: Shown without companion flange

Units	A	B	C	D	E	F	G	H	J
US Customary	39	19.5	13.75	27.5	18.88	20	31.6	15	11.6
S.I.	991	495	349	699	480	508	803	381	295

Units	K	L	M	N	P	Q	R	U	Y
US Customary	5.15	23.2	12.75	25.5	9.5	30	19	2.25	0.88
S.I.	131	589	324	648	241	762	483	57	22

(All dimensions are for new OEM supplied units)

Standard Included Components

- Load Cell and Linkage
- Cooling Safety Package
- Calibration Arm
- Calibration Weight Hanger
- Companion Flange / Hub Pattern 1550 - US Customary
- Shaft End Guard
- Magnetic Pickup and 60-tooth Gear
- Constant Level Oilers

Everything you need to succeed



Dyne Systems is a division of Taylor Dynamometer
 W209 N17391 Industrial Dr., Jackson, WI 53037
 (800) 657-0726 www.dynesystems.com

DS2371v002